

# JUNIOR-SCREEN

NEW

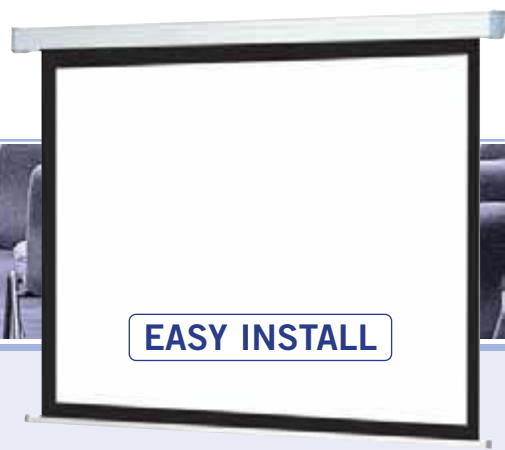

## CHARACTERISTICS

- White painted galvanised steel casing (RAL 9016).
- Tubular motor with brake (5- year guarantee) and thermal circuit breaker.
- Easy to install on the wall or ceiling.
- The spacing between the mounting brackets can be adjusted to suit the installation constraints.
- Plug & go electrical connection system.
- Available with Matte White P and Matte White C fabric.
- 2.5 m connection cable.
- 3- position switch.
- All the electric screens from PROCOLOR comply with EN 60335-1 and EN 60335-2-97.
- 4:3 and 16:9 formats with 2.5 cm all-round black border to enhance the colour contrast.
- 1:1 format without border.

## ACCESSORIES / pp. 59-63



+ Easy Install Accessories p.62

## Wall and ceiling mounting MULTIPURPOSE

This screen is especially recommended for classrooms or conference rooms. The Easy Install mounting system makes the screen easier to install.

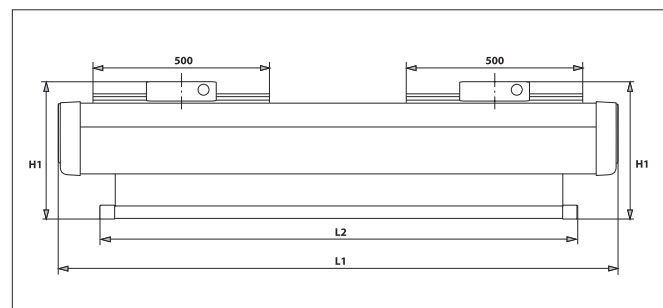
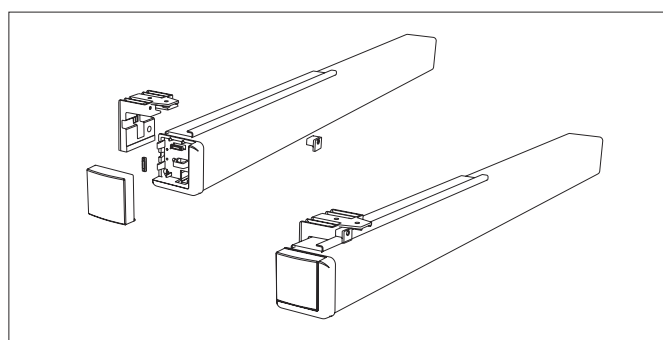
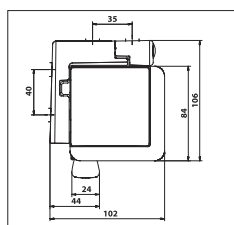
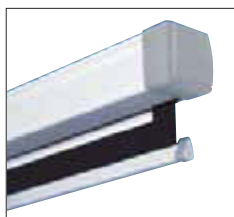

Dimensions are given in mm.

	Overall	Image size	Diagonal	Fabrics		Dimensions (cm)			Power	Speed	Net weight
	WxH (cm)	WxH (cm)	(cm)	Matte White P	Matte White C	H1	L1	L2	W	rpm	Kg
<b>1:1</b>	156x156	156x156	220	094360		169	171	162	124	30	11
	176x176	176x176	248	094380		189	191	182	124	30	13
	198x198	198x198	280	094320		211	213	204	124	30	15
	238x238	238x238	336	094310		251	253	244	124	30	19
<b>4:3</b>	156x118	151x113	188	094330		131	171	162	124	30	11
	176x133	171x128	213	094340		146	191	182	124	30	13
	198x150	193x145	241	094350		163	213	204	124	30	15
	238x180	233x175	291	094390		193	253	244	124	30	19
	278x210	273x205	341		094370	223	293	284	124	30	23
<b>16:9</b>	176x101	171x96	196	094341		114	191	182	124	30	13
	198x114	193x109	221	094351		126	213	204	124	30	15
	238x136	233x131	267	094391		149	253	244	124	30	19
	278x158	273x153	312		094371	171	293	284	124	30	23

W: Image width H: Image height H1: Total screen height L1: Length of casing L2: Length of bottom bar